



# **SURE STAR COMPUTER CO., LTD**

NO.2-1,DAAN ROAD, SHULIN .DIST., NEW TAIPEI CITY 238 , TAIWAN.

e-mail: info@surestar.com.tw

tel: +886 2 2682 2505

http://www.surestar.com.tw

fax: +886 2 2682 2515

## **2U/3U Redundant Power Supply**

### **350W for IPC-Computer**

**Model No. TC-350R2U**

**Revision: A1**

Table of content

<b>1. Introduction</b> .....	2
<b>2. Specification</b>	
2.1 Input Voltage.....	2
2.2 DC Output.....	2
2.3 PS-ON (Remote ON/OFF).....	3
2.4 PW-OK(power good signal).....	3
2.5 Efficiency.....	3
2.6 Hold-Up Time.....	3
<b>3. PROTECTION</b>	
3.1 Over Voltage protection.....	3
3.2 Short Circuit Protection.....	3
3.3 Over Power Protection.....	3
3.4 No Load operation.....	4
<b>4. Environment Temperature</b> .....	4
<b>5. Reliability</b> .....	4
<b>6. Agency approvals</b> .....	4
<b>7. EMI/RFI</b> .....	4
<b>8. Instructions</b> .....	4
<b>9. HOT-SWAP Procedures</b> .....	5
<b>10. Dimension</b> .....	5
<b>11.PINOUTS of connectors</b> .....	6
*Color Reference for LED cable.....	6
*Main Power Connector.....	6

## 1. Introduction

The 350R2U Series products of **Hot-Swap & Power Sharing** redundant Power supply provides increased reliability when integrated a variety of Systems. The 350R2U series is ideally suited to telecommunications and Industrial system, as well as a variety of other applications where system Never shut down i. E. Zero down time.

**TC-350R2U** series redundant power supply, it consists of

- \* One of passive Back plane.
- \* One of exothermal enclosure.
- \* Two of compact size power modules with Hot-Pluggable connector
- \* Screw package.
- \* Alarm reset bottom.

### ©Features

- \* 2U Size design.
- \* Hot-Swappable & Power Sharing capability.
- \* Full Range AC input.
- \* PFC meet

## 2. Specification

2.1 AC Input Voltage: 100 to 240VAC 47Hz~63 Hz.

2.2 DC Output: 350W maximum

VOLTAGE	+5V	+12V	+3.3V	-12V	-5V	+5Vsb
MAX. LOAD	25A	22A	25A	0.8A	0.5A	2A
MIN. LOAD	3A	2A	0.3A	0.1A	0.1A	0.1A
REGULATION	± 5%	± 5%	± 5%	±10%	±10%	± 5%
RIPPLE(mV)	50	120	50	120	100	50

### Note:

1. The combined total power from +5V and +3.3V shall not exceed 40A.  
The combined total power from +5V and +3.3V & +12V shall not exceed 328W
2. Noise Test – Noise bandwidth is from DC to 20 MHz.
3. Ripple frequencies greater than 1MHz shall be attenuated by the measurement System.
4. Add 0.1uF/10uF capacitor at output connector terminals for ripple and noise measurements.

## 2.3 PS-ON

### Remote On/Off Control:

When PS-ON is pulled to TTL Low, the DC output is to be enabled.

When PS-OFF is pulled to TTL high, the DC output is to be disabled.

## 2.4 PW-OK

PW-OK is power good signal and should be asserted high by the power supply to indicate that +5VDC and +3.3VDC output are above the under voltage thresholds of the power supply TTL. compatible signal out with 100ms to 500ms.

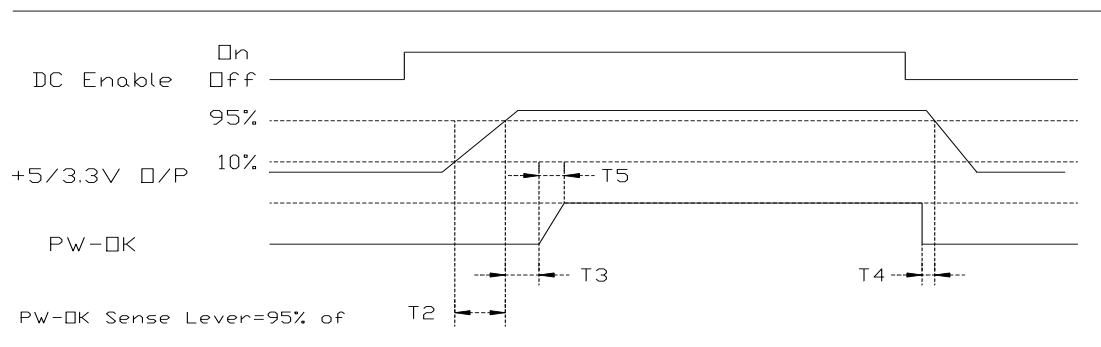

### Timing of PS-ON, PW-OK, and Germane Voltage Rails

Although there is no requirement to meet specific timing parameters,

The following signal timings are recommended:

$$2\text{ms} \leq T2 \leq 200\text{ms}$$

$$100\text{ms} \leq T3 \leq 500\text{ms}$$

$$T4 > 1\text{ms}$$

$$T5 \leq 10\text{ms}$$

2.5 Efficiency:  $\geq 73\%$  at full load. (Normal Line)

2.6 Hold-Up Time: 16ms at maximum load & normal input voltage.

## 3. PROTECTIONS

### 3.1 OVER-VOLTAGE PROTECTION

Standard on +5.0V output, set at  $6.25\text{VDC} \pm 0.75\text{VDC}$ .

### 3.2 SHORT CIRCUIT PROTECTION

A short circuit placed between the DC Return and the output shall cause

No damage and the power supply shall shutdown.

### 3.3 OVER POWER PROTECTION

The power supply shall shut down when output power exceeds 130% to 160% of full load and require a power on cycle be performed by the operate

### 3.4 NO LOAD OPERATION

No parts shall be damaged on the power supply.

## 4. ENVIRONMENT TEMPERATURE

4.1 Operation Temperature: 0°C to 40°C

4.2 Cooling: By forced air

4.3 Storage Temperature: -20°C to 70°C

4.4 Humidity: 5 to 90% non-condensing.

## 5. RELIABILITY

### 5.1 MTBF OF POWER SUPPLY ELECTRONIS

100,000 hours at full load and 25°C ambient temperature

### 5.2 LIFE EXPECTANCY OF FAN

40,000 hours at 40°C

## 6. AGENCY APPROVALS

UL 60950-1, 2<sup>nd</sup> Edition

TUV ( EN60950-1: 2006+A11+A1+A12)

IEC 60950-1: 2005+A1

C-Tick AS/NS CISPR 22: 2006 (Class A) / CISPR 22: 2008 (Ed 6.0)

BSMI CNS14336-1, CNS13438

CCC GB4943.1-2011

## 7. EMI /RFI

FCC part 15, Class A (Verification) IC ICES-003

EN55022 : 2006+A1: 2007 (Class A)

EN55024 : 1998+A1: 2001+A2: 2003

EN61000-3-2: 2006

EN61000-3-2: 2008

IEC61000-4-2, -3, -4, -5, -6, -8, -11

## 8. INSTRUCTIONS

The set still works properly even if either unit is removed. The removed unit can't be used in other machinery nor for other purpose. When one unit breaks down, it's LED will blink, buzzer will sound. Push the Reset button and buzzer will stop.

**REDUNDANCY** Offer redundant function for power system and mutually backs up the outputs. A zero transfer time when backup takes place.

**HOT-SWAP** The power system provides a Hot-Swap function. This means when either one of the redundant power supplies fails or breaks down, you can easily replace failed unit without any interference to the system.

BUZZER	A warning buzzer sounds when any one of the power supplies fails. The warning buzzer is reset table from reset switch either the one in front control panel or the one on the rear side.
LED'S	The warning LED'S can be found either on the rear side or the control panel of the power system. Tells if one of the two power supplies has failed, by LED blinking.
HOT-PLUGGABLE	The power system provides a Hot-Pluggable function. This method allows the power units in the Disk Array/ File Server to be removed or inserted very easily without

## 9. HOT-SWAP PROCEDURES

Please refer to the followings when either one power supply unit is found defective.

- A) **Locate** the defective power supply by examining the individual LED on the power unit or the LED on the front control panel if LED is Blinking.
- B) **Unlock & Remove** the defective power supply unit.
- C) Replace a new GOOD power supply unit, Insert the power supply into the power system chassis in position & it will auto Lock-up.
- D) Turn on the new power supply unit.
- E) Check the module LED which indicate the power and LED of total power system status, Both LED shall Have steady life.

## 10. DIMENSION

TC-XXXR2U L 280 x W101 x H 84 mm

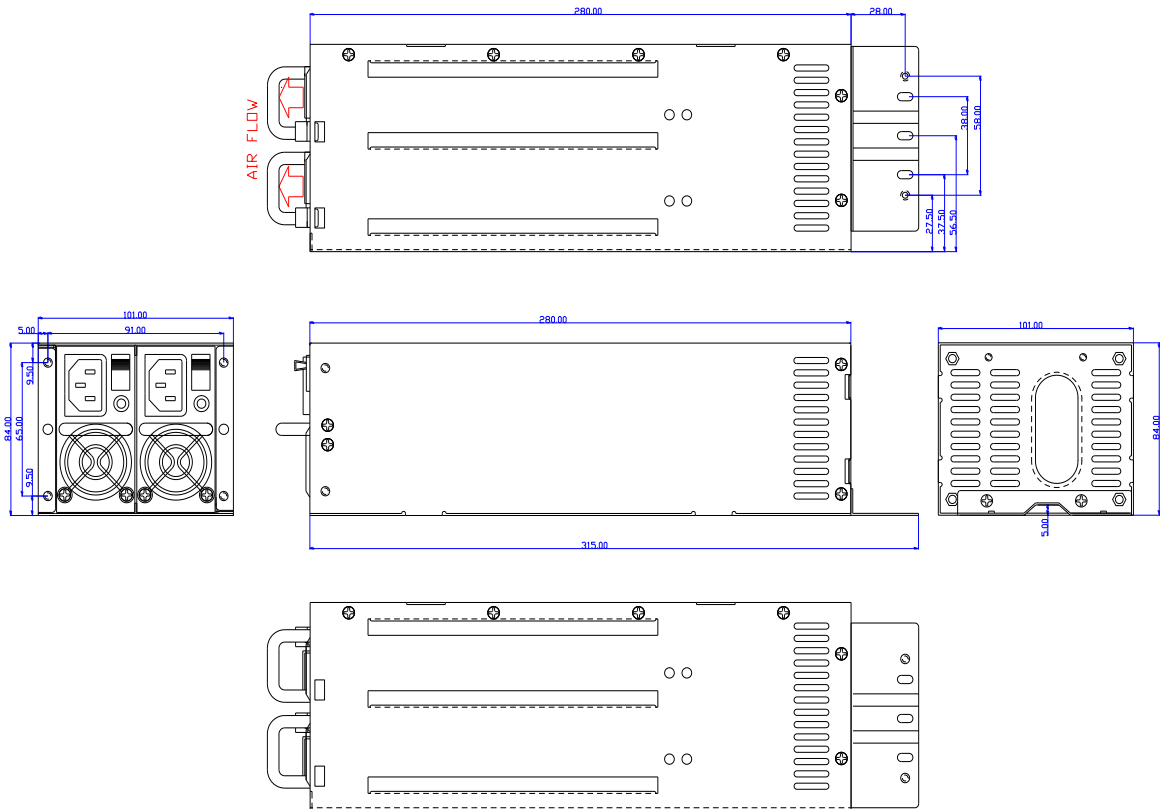

## 11. PINOUTS OF CONNECTORS

EPS 24Pin x 1 , M8P +12V Power Connector x 1 , M4P +12V Power Connector x 1 ,  
H.D.D. x 5 , Floppy x 1, Serial ATA HDD x 2.

### \* Color Reference for LED cable

MAIN POWER LED Cable                      Green / with

### \* Main Power Connector

REVISIONS			
REV	DESCRIPTION	SIGN	DATE
03			/ /

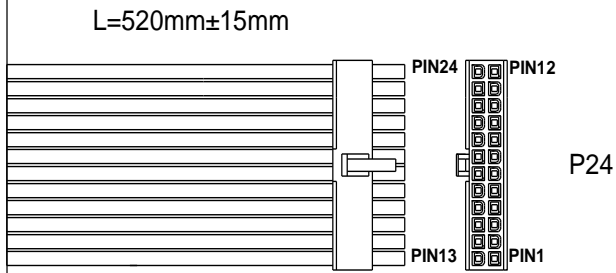

**24Pins(EPS12V)**  
**Connector HOUSING: MOLEX 39-01-2240 or equivalent**  
**TERMINAL: MOLEX 39-00-0039 or equivalent**

Housing	Pin No.	WIRE COLOR	LENGTH	Pin No.	WIRE COLOR	LENGTH
P24	1	PURPLE(+3.3V)	520mm/18AWG	13	PURPLE(+3.3V)	520mm/18AWG
	2	PURPLE(+3.3V)	520mm/18AWG	14	PURPLE(+3.3V)	520mm/22AWG
	3	BLACK(GND)	520mm/18AWG	15	BLUE(-12V)	520mm/18AWG
	4	RED(+5V)	520mm/18AWG	16	BLACK(GND)	520mm/18AWG
	5	RED(+5V)	520mm/18AWG	17	GRAY(PS-ON)	520mm/20AWG
	6	BLACK(GND)	520mm/18AWG	18	BLACK(GND)	520mm/18AWG
	7	RED(+5V)	520mm/18AWG	19	BLACK(GND)	520mm/18AWG
	8	BLACK(GND)	520mm/18AWG	20	BLACK(GND)	520mm/18AWG
	9	ORANGE(PG)	520mm/18AWG	21	WHITE(-5V)	520mm/18AWG
	10	BROWN(+5VSB)	520mm/18AWG	22	RED(+5V)	520mm/18AWG
	11	YELLOW(+12V)	520mm/18AWG	23	RED(+5V)	520mm/18AWG
	12	YELLOW(+12V)	520mm/18AWG	24	BLACK(GND)	520mm/18AWG

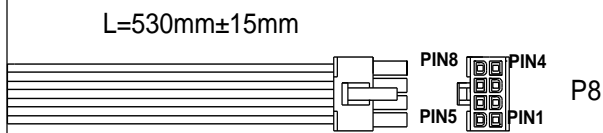

**8Pins(EPS12V)**  
**Connector HOUSING: MOLEX 39-01-0280 or equivalent**  
**TERMINAL: MOLEX 39-00-0060 or equivalent**

Housing	Pin No.	WIRE COLOR	SIGNAL	WIRE TYPE	LENGTH
P8	1	BLACK	COM	18AWG	530mm ±15mm
	2	BLACK	COM	18AWG	
	3	BLACK	COM	18AWG	
	4	BLACK	COM	18AWG	
	5	YELLOW	+12V	18AWG	
	6	YELLOW	+12V	18AWG	
	7	YELLOW	+12V	18AWG	
	8	YELLOW	+12V	18AWG	

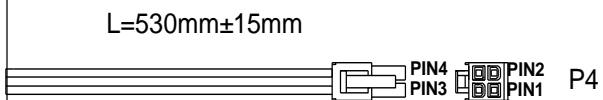

**4Pins(ATX12V, FOR P4)**  
**Connector HOUSING: MOLEX 39-01-0280 or equivalent**  
**TERMINAL: MOLEX 39-00-0060 or equivalent**

Housing	Pin No.	WIRE COLOR	SIGNAL	WIRE TYPE	LENGTH
P4	1	BLACK	COM	18AWG	530mm ±15mm
	2	BLACK	COM	18AWG	
	3	YELLOW	+12V	18AWG	
	4	YELLOW	+12V	18AWG	

設計公差: TOLERANCES: XXX= XX= X=	材料規格 MATERIAL	審核者 APPROVE BY.	繪圖者 DRAW BY.	單位 UNITS	mm	
投影法: PROJECTION: 第三角法		日期 DATE	日期 DATE	圖號 SHEET	OF	
			Kevin			TC-R2U HARNESS
				日期 DATE	2010,12,23	料號 PART NO

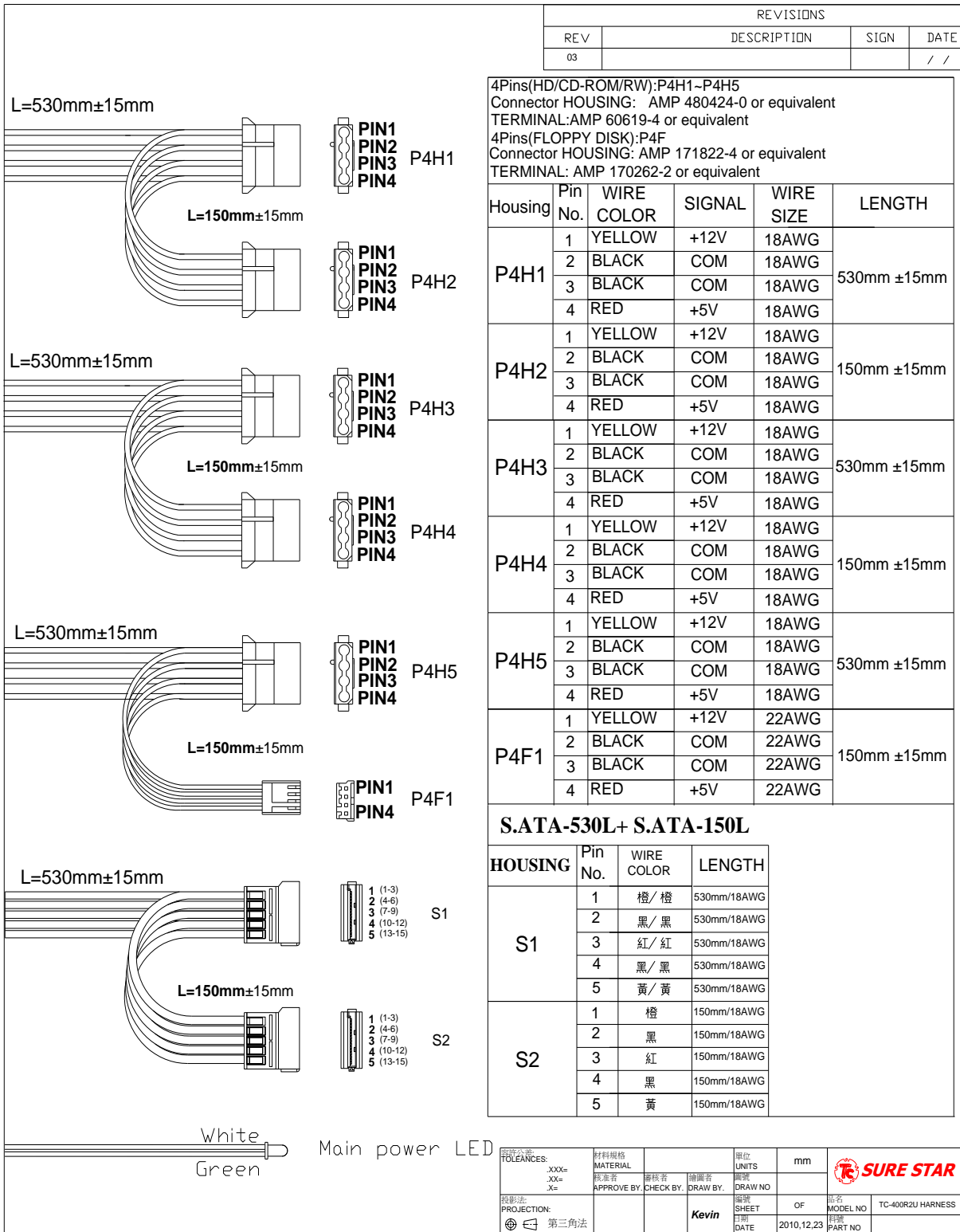

**Note: Specification and wiring diagram subject to change without notice.**

2014/9/18